

REVISIONS				
ZONE	REV.	DESCRIPTION	APPROVED	DATE

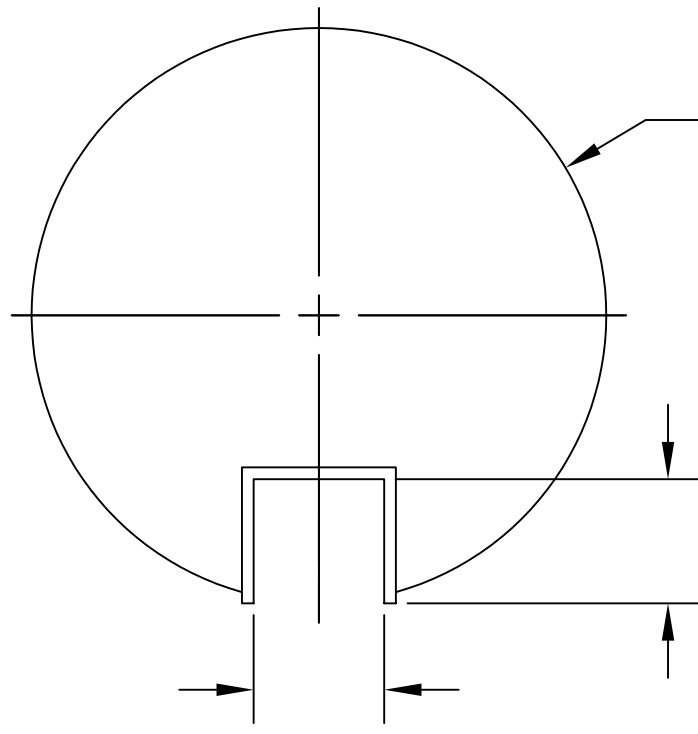
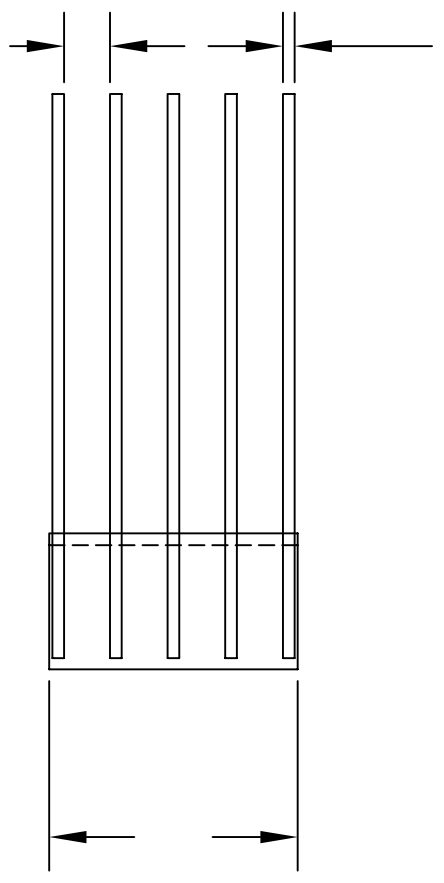

UNLESS NOTED BREAK ALL EDGES 0.010" MINIMUM

**PROPRIETARY**

THE INFORMATION CONTAINED HEREIN IS THE PROPERTY OF UNITED SILICA PRODUCTS INC., AND MAY NOT BE REPRODUCED OR DISCLOSED IN WHOLE OR IN PART WITHOUT THE WRITTEN PERMISSION OF UNITED SILICA PRODUCTS INC.

FILE NAME: TITLE.DWG REV.1

TOLERANCES	
DECIMAL INCHES	MILLIMETERS
X.X = +/-0.1	X = +/- 1
X.XX = +/-0.02	X.X = +/-0.5
X.XXX = +/-0.010	X.XX = +/-0.25
ANGULARITY +/- 1°	
FRACTIONS +/-1/8"	
QTZ. TUBE PER GE STD. TOL.	

UNITED SILICA PRODUCTS, INC.  
 3 PARK DRIVE, FRANKLIN, NEW JERSEY 07416  
 PH (973) 209-8854 FAX (973) 209-8864  
 E-MAIL quartzsales@unitedsilica.com

TITLE: **BAFFLE**

CUST.	DWG NO.	REV.
MATERIAL GE124/EQ		DRAWN BY
		APPROVED BY
SCALE NONE	SHEET	DATE